

GENEL NOTLAR

- 1- BİTİRİLMİŞ VEYA BİTİRİLMİYEN KISIMLAR
- 2- BİTİRİLMİŞ VEYA BİTİRİLMİYEN KISIMLAR
- 3- ÇİZİM MALZEMELERİNE İLİŞKİLİ NOTLAR
- 4- ÇİZİM MALZEMELERİNE İLİŞKİLİ NOTLAR
- 5- ÇİZİM MALZEMELERİNE İLİŞKİLİ NOTLAR
- 6- ÇİZİM MALZEMELERİNE İLİŞKİLİ NOTLAR

WELD SYMBOL & DESCRIPTIONS

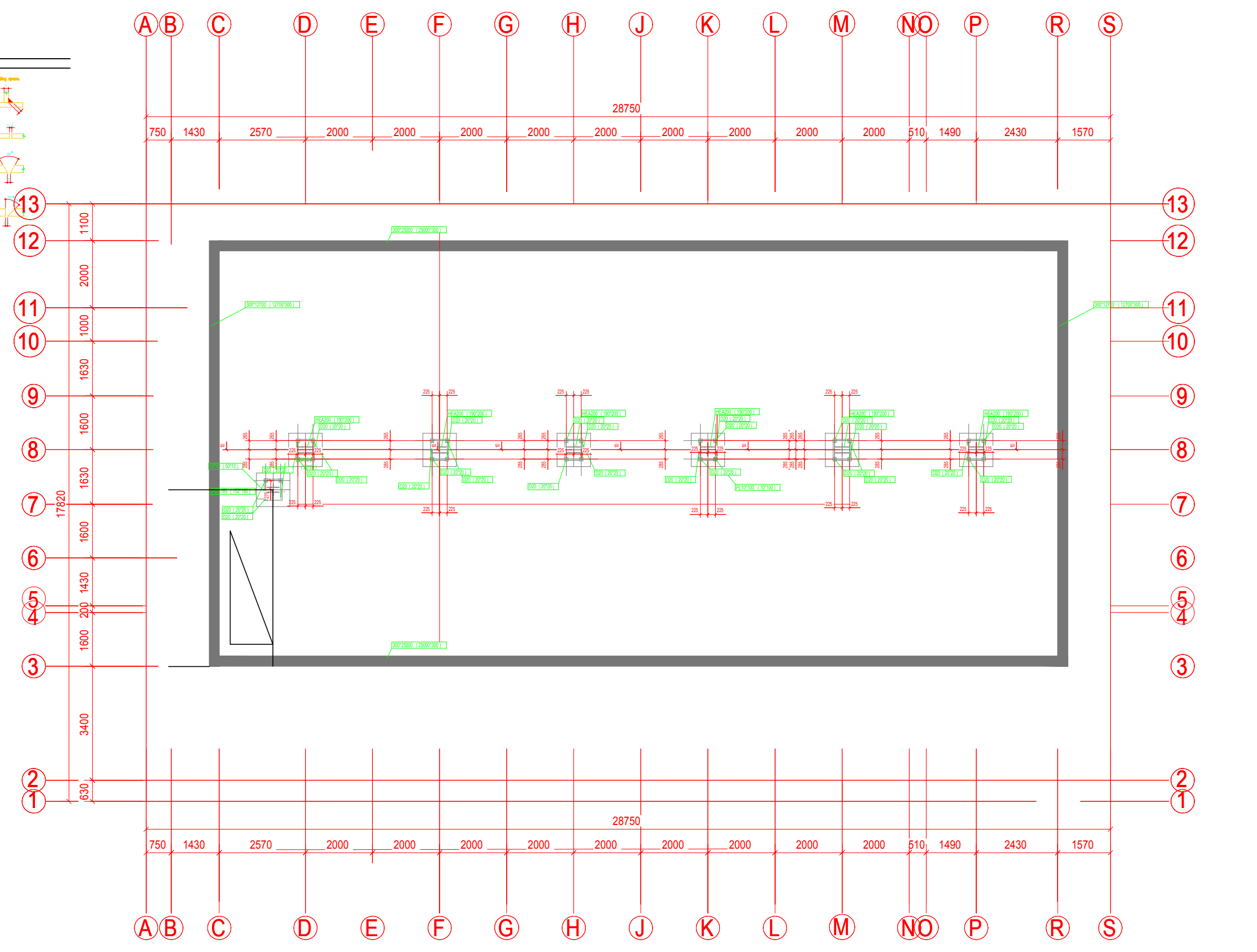
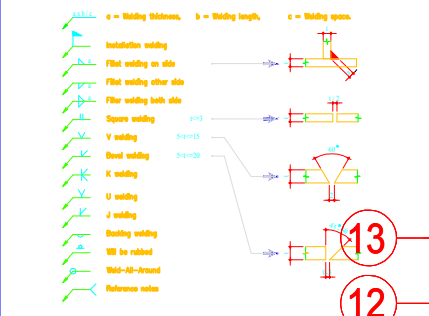

-2.40(0.00) KOTU TEMEL PLANI

No	REV MARK	REVISION DESCRIPTION	CREATED	APPROVED	REV. DATE
DRAWING TITLE		BİLGİ ÖNÜ DOLAPDERE KAMPÜSÜ TADLAT PLANI			
PROJECT NAME		-2.40 KOTU YERLEŞİM PLANI			
DESIGNER		ISSUE DATE			
PROJECT No.		SCALE 1:50			
DRAWING No.		REVISION No. 0			

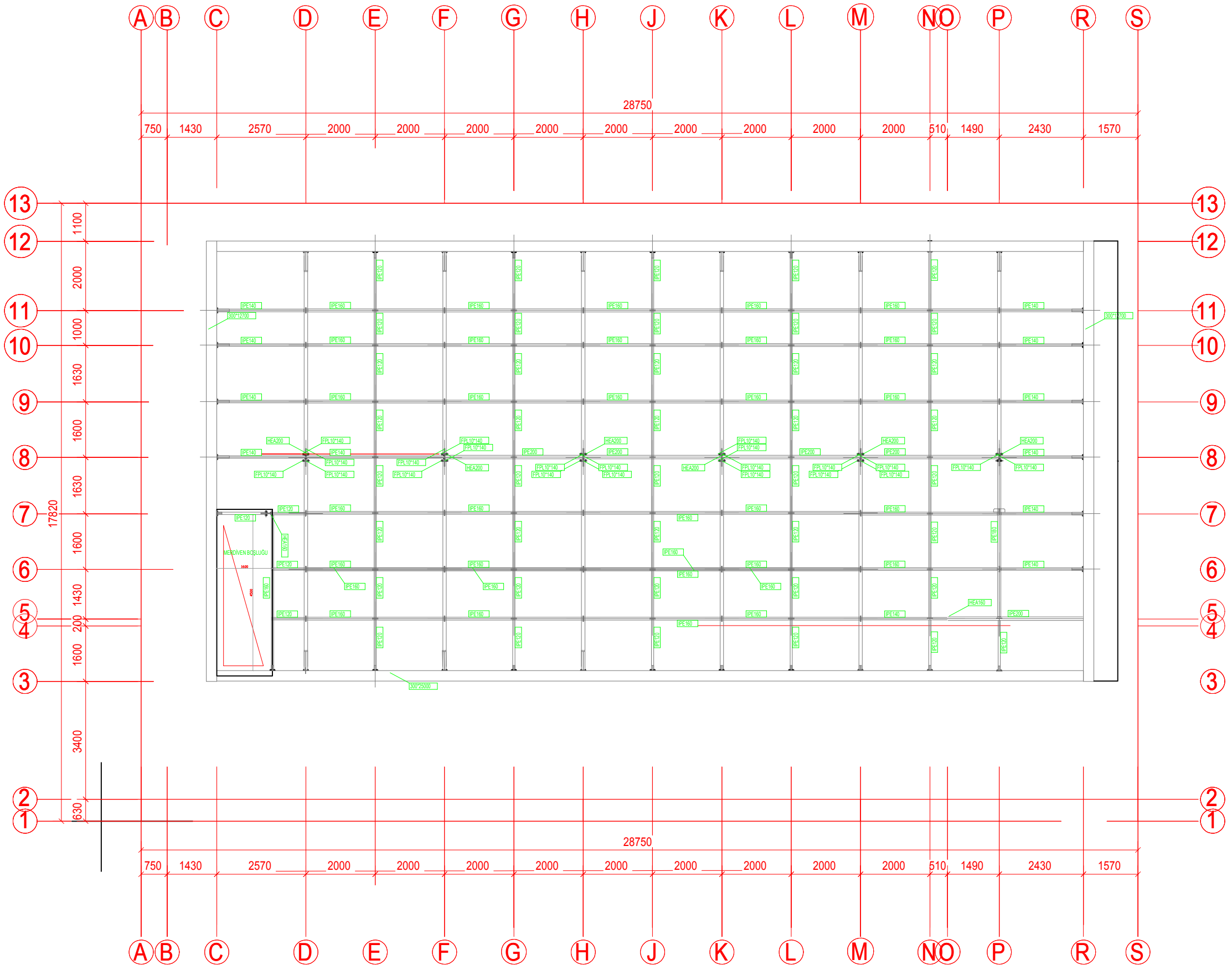

+ 0.00 (+2.40) KOTU ÇERÇEVE PLANI

No	REV. MARK	REVISION DESCRIPTION	CREATED	APPROVED	REV. DATE
DRAWING TITLE: 0.00 (+2.40)KOTU ÇERÇEVE PLANI					
PROJECT NAME: Tekla Corporation					
DESIGNER:				ISSUE DATE:	
PROJECT No: 1			SCALE: 1:50		
DRAWING No: (3)			REVISION No: 0		

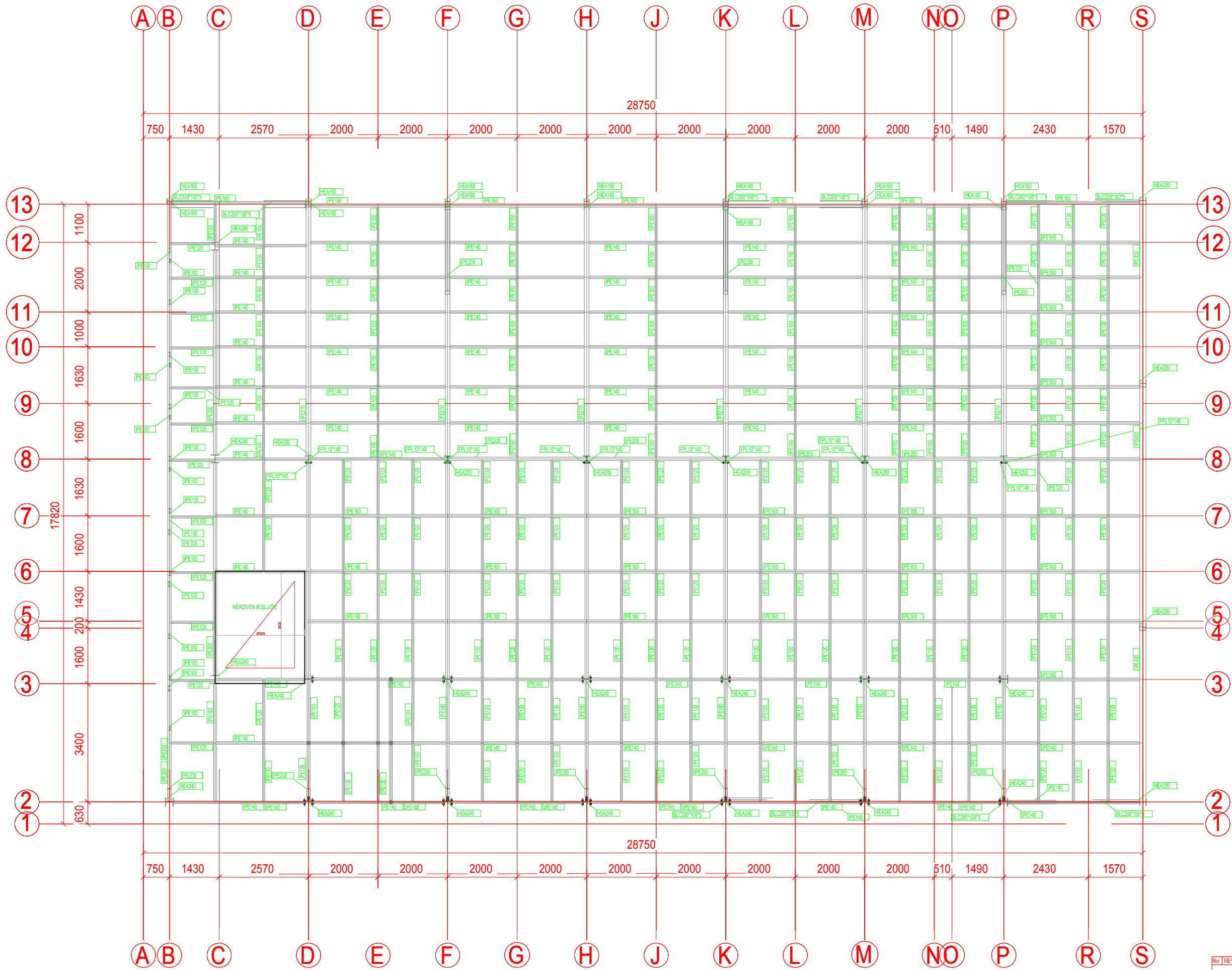

No	REV MARK	REVISION DESCRIPTION	CREATED	APPROVED	REV. DATE
----	----------	----------------------	---------	----------	-----------

DRAWING TITLE	ZEMİN KAT +2.80(+5.20) KOTU ÇERÇEVE PLANI	
PROJECT NAME	Taktik Corporation	
DESIGNER		ISSUE DATE
PROJECT No.	1	SCALE 1:50
DRAWING No.	[22]	REVISION No. 0

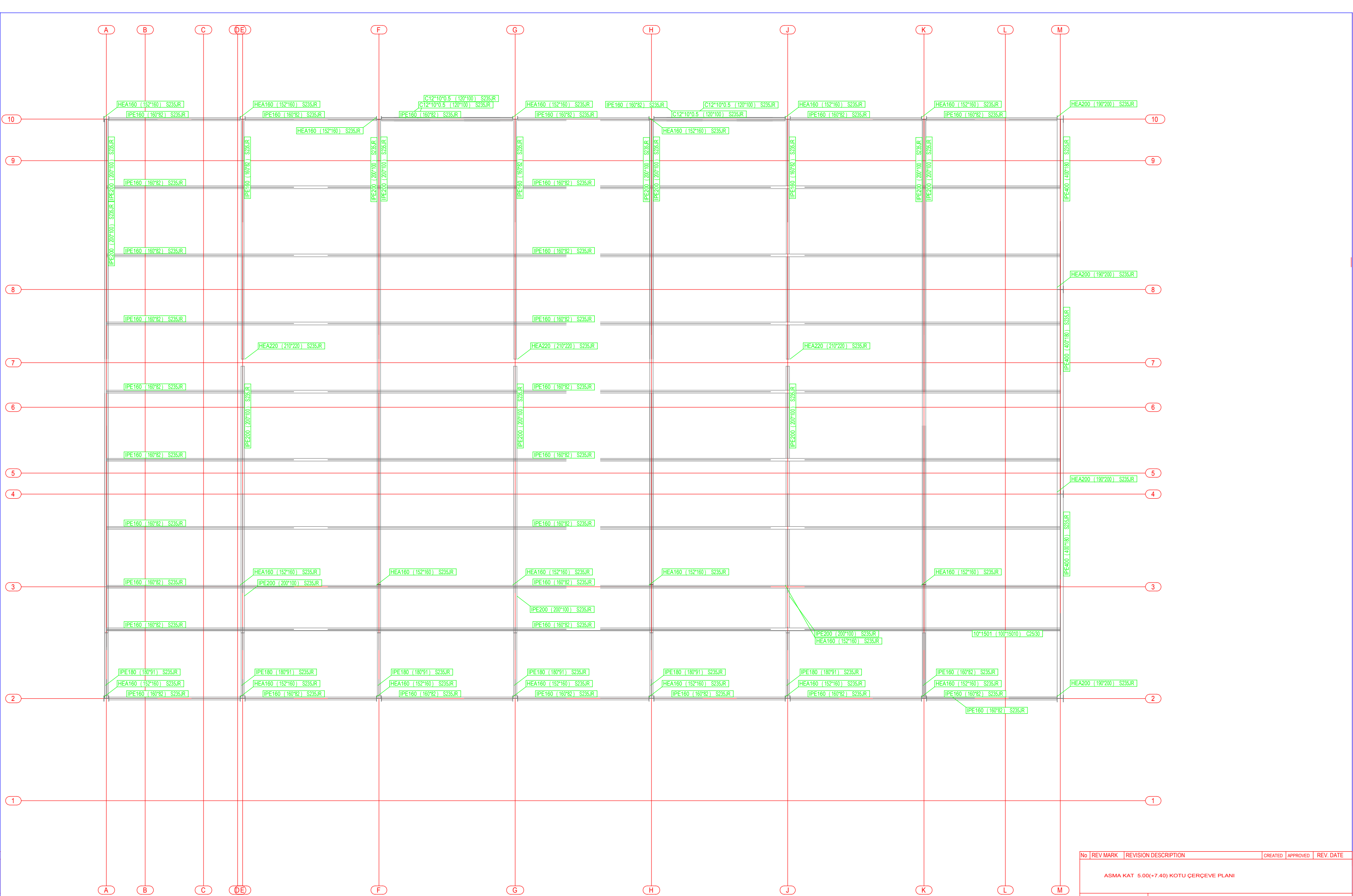

PLAN +5000

No	REV MARK	REVISION DESCRIPTION	CREATED	APPROVED	REV. DATE
ASMA KAT 5.00(+7.40) KOTU ÇERÇEVE PLANI					
DRAWING TITLE		Elevations			
PROJECT NAME		Tekla Corporation			
DESIGNER		ISSUE DATE			
PROJECT No.		1		SCALE 1:50	
DRAWING No.		[1]		REVISION No. 0	

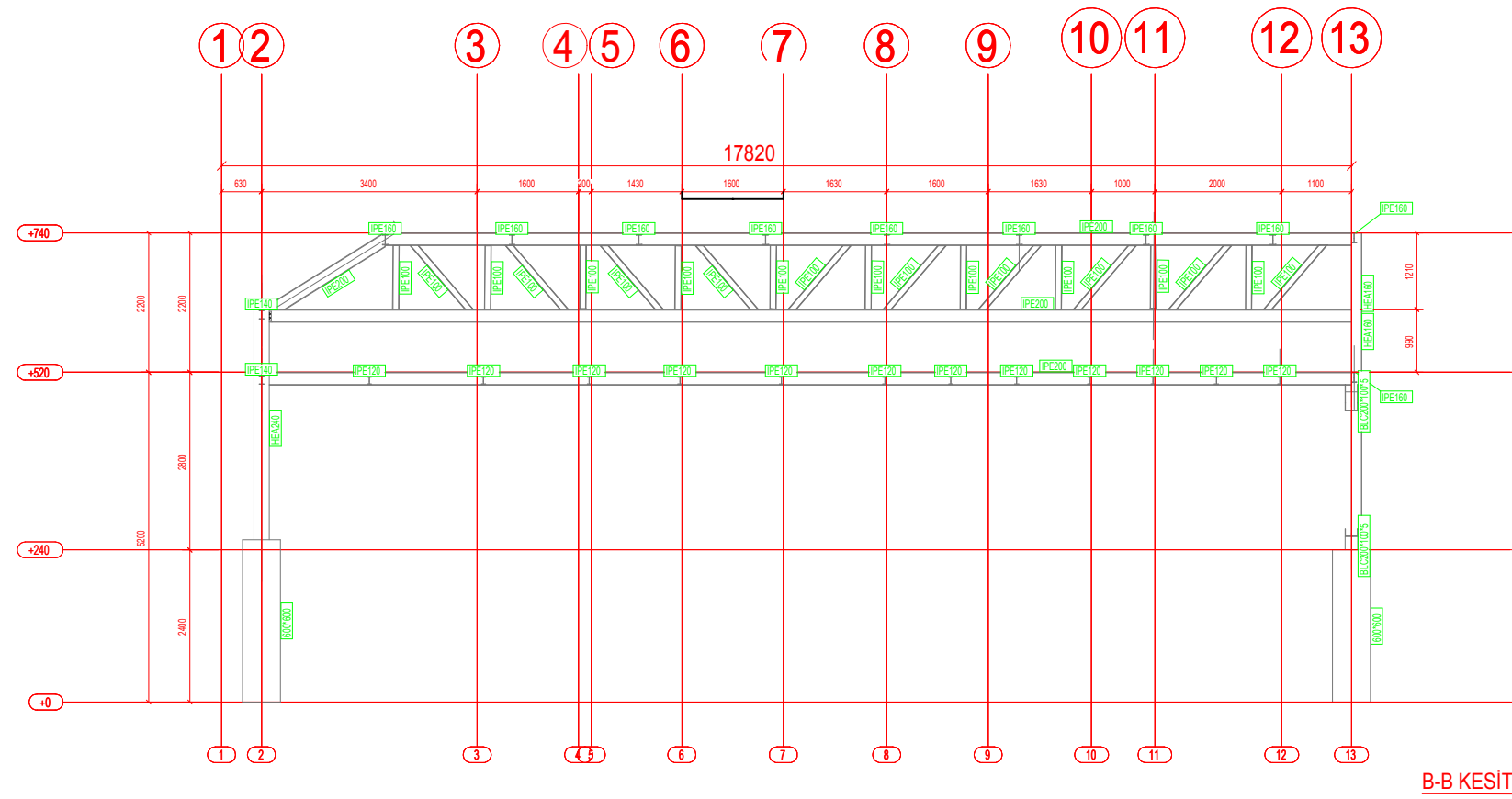

B-B KESİTİ

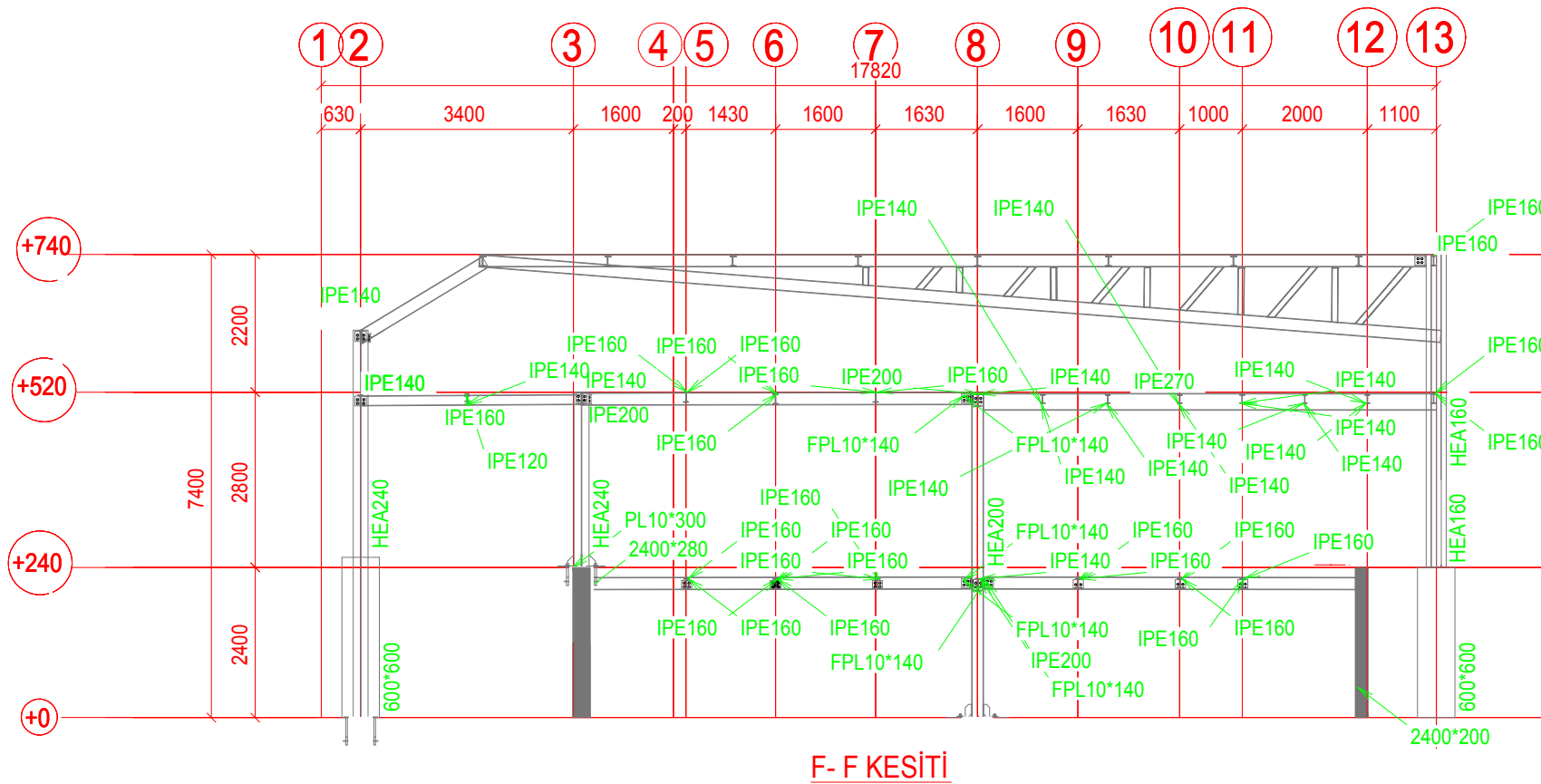

F-F KESİTİ

Rev	Description	Date	Created	Approved
Client				
Project		Project Number		
Tekla Corporation				
Drawing Title				
PLAN AT LEVEL X				
B-B / F-F KESİTİ				
Drawn by	Scale @A1	1:100		
Designed by	Date			
Checked by	Drawing Number	ENTER DRG		
Approved by	Revision			

46
Fekle strukture
PHASE
1

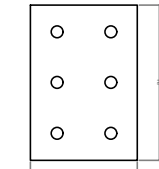

PL/37
15
MM

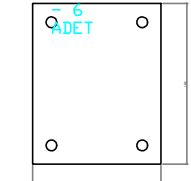

PL/35 10
MM
- 3
ADET

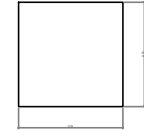

PL/21

-
15
mm
62

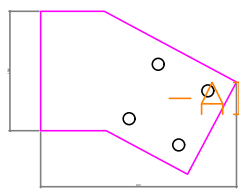

PL/25

-
15
mm
10

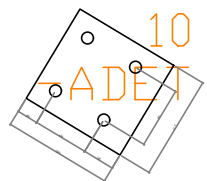

PL/19

-
15
mm
62

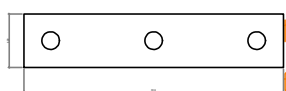

PL/31

-
20
mm
18

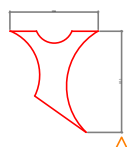

PL/32
10
MM
-
40
ADET

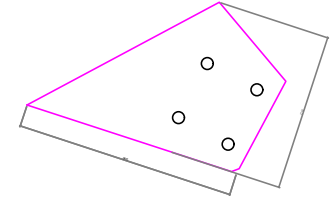

PL/24

-
15mm
6

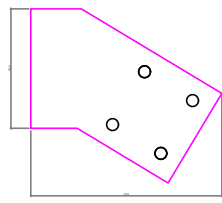

PL/26

-
15
mm
18



PL/23

-
15
mm
54

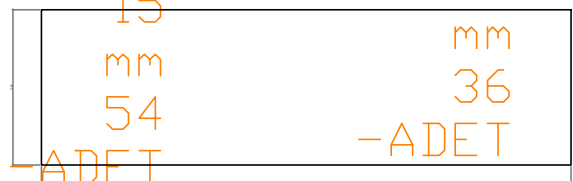

PL/35

-
10
mm
40

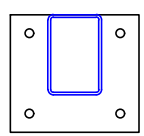

PL/18
10
MM
-
16
ADET

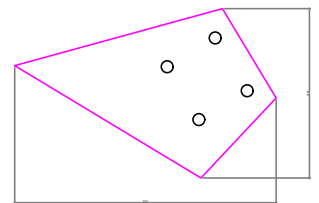

PL/20

-
15
mm
18

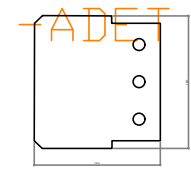

PL/7
10
MM
- 4
ADET

PL/27

-
15
mm
18

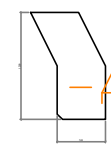

PL/28

-
15
mm
36



PL/11

-
10
mm
116

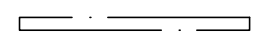

DUZ
KESİM
/
PL/36
-
10
mm

PL/34 10
MM
-
80
ADET

990*1075
- 4
-ADET

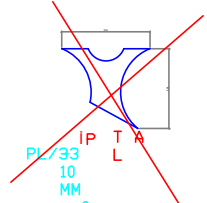

PL/33
10
MM
- 0
ADET

GRID LOCATION	
B18	J-K/8

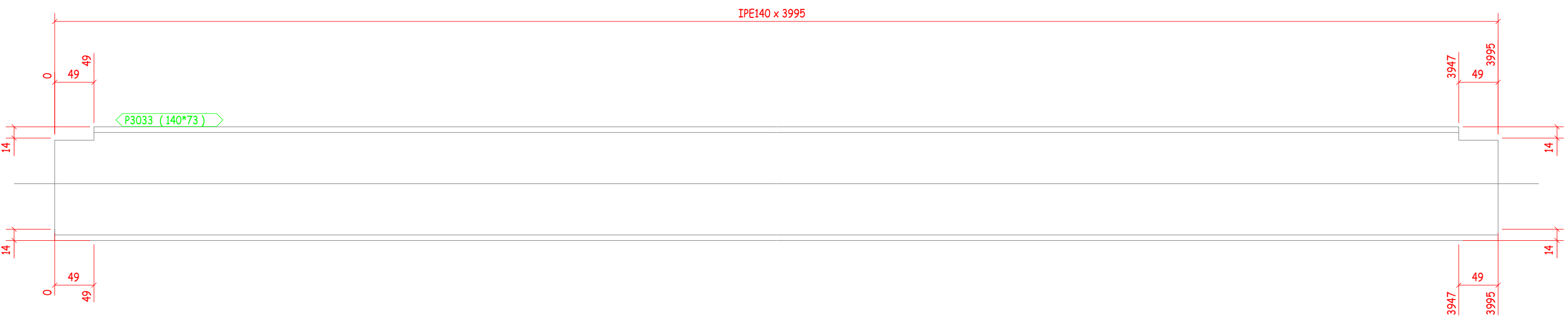

1 No BEAM Marked B18

GENERAL NOTES:						
			ALL HOLES ARE	22.0	mm UNLESS NOTED	
			ALL WELDS ARE	6.0	mm F.W UNLESS NOTED	
MATERIAL LIST FOR ASSEMBLY MK'D						
			B18		1	No. Required
Mark	Profile	Material	No.	Length	Area	Weight
P3033	IPE140	S235JR	1	3995	2.2	51.4
				Total	2.2	51.4

No	REV MARK	REVISION DESCRIPTION	REV. DATE
DRAWING TITLE		COLUMN	
CONTRACT		Tekla Corporation	
MODELLED BY		ISSUED	
CONTRACT NO		1	SCALE 1:5
DRAWING No		[B.18]	REVISION No. 0

PHASE	QUANTITY	FINISH
1	1	

A3

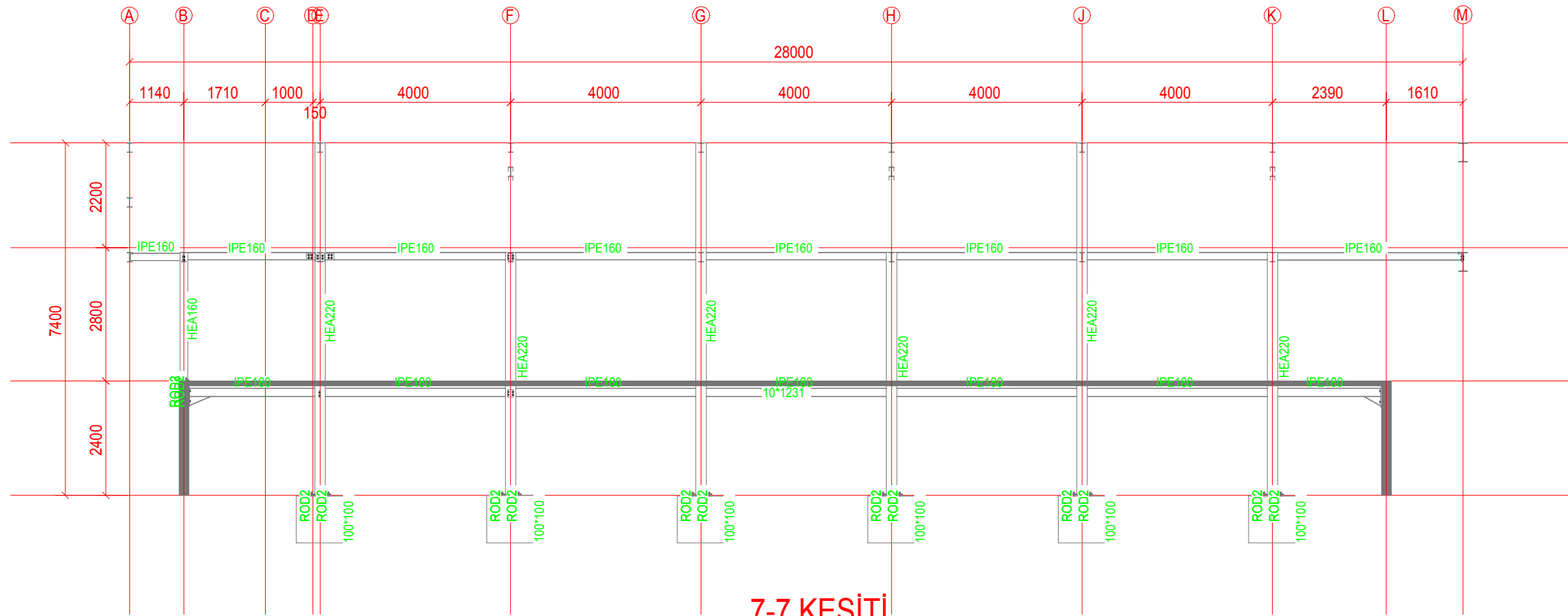

7-7 KESİTİ

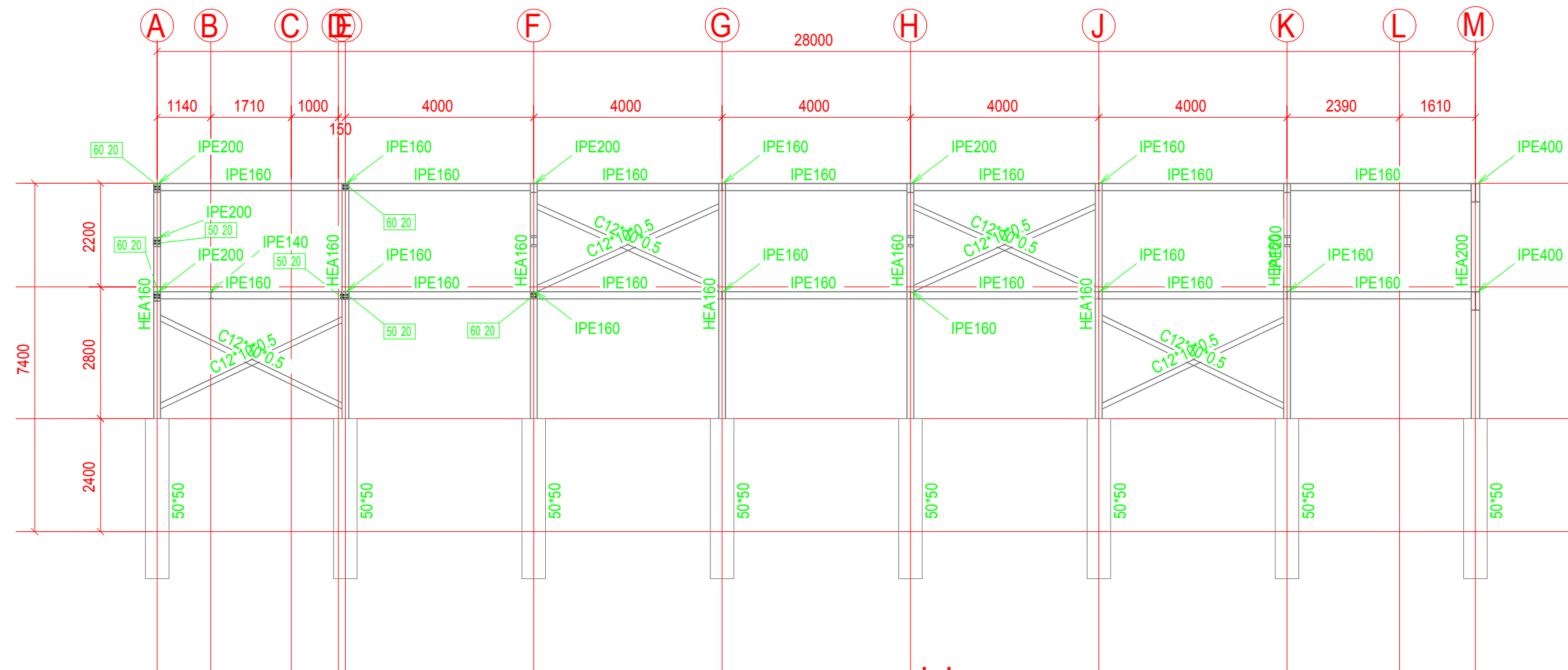

10-10 KESİTİ

Rev	Description	Date	Created	Approved

Client
Project
Project Number 1

Tekla Corporation
Drawing Title
3D VIEW OF STRUCTURE

Drawn by
Designed by
Checked by
Approved by
Scale @A1
Date
Drawing Number ENTER DRG
Revision

High Product

GRID LOCATION	
	K-M/7-8
	K-M/8-9

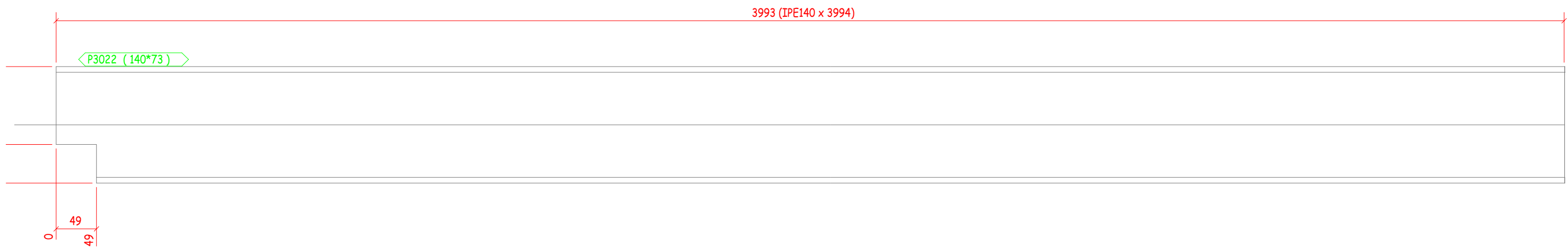

3 No BEAM Marked B15

GENERAL NOTES:		ALL HOLES ARE	22.0	mm UNLESS NOTED		
		ALL WELDS ARE	6.0	mm F.W UNLESS NOTED		
MATERIAL LIST FOR ASSEMBLY MK'D		B15 3 No. Required				
Mark	Profile	Material	No.	Length	Area	Weight
P3022	IPE140	S235JR	1	3994	2.2	51.4
			Total		2.2	51.4

No	REV MARK	REVISION DESCRIPTION	REV. DATE
DRAWING TITLE		COLUMN	
CONTRACT		Tekla Corporation	
MODELLED BY		ISSUED	
CONTRACT NO		1	SCALE 1:5
DRAWING No		[B.15]	REVISION No. 0

QUANTITY	FINISH
3	

A3

GRID LOCATION	
B20	K-M/2-3

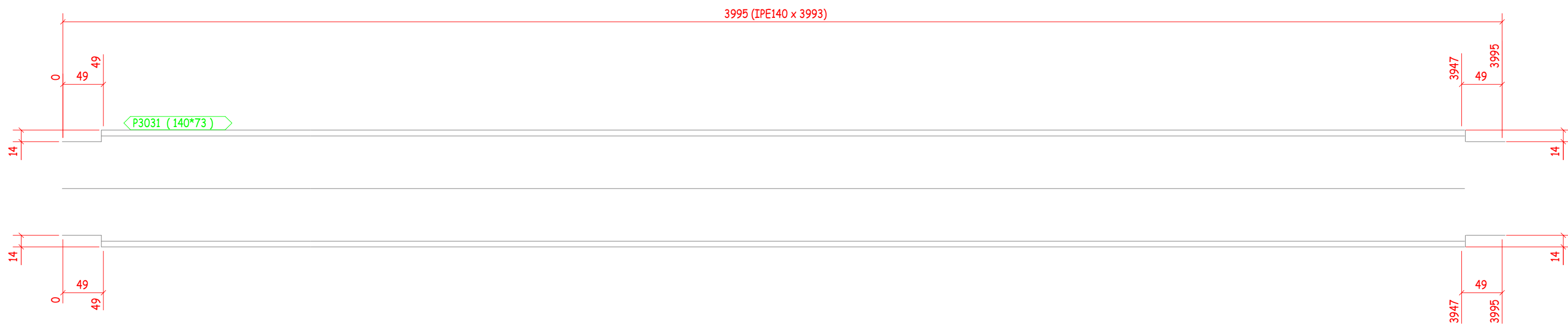

1 No BEAM Marked B20

GENERAL NOTES: ALL HOLES ARE 22.0 mm UNLESS NOTED
ALL WELDS ARE 6.0 mm F.W UNLESS NOTED

MATERIAL LIST FOR ASSEMBLY MK'D						
			B20		1 No. Required	
Mark	Profile	Material	No.	Length	Area	Weight
P3031	IPE140	S235JR	1	3993	2.2	51.4
				Total	2.2	51.4

No	REV MARK	REVISION DESCRIPTION	REV. DATE
DRAWING TITLE		COLUMN	
CONTRACT		Tekla Corporation	
MODELLED BY		ISSUED	
CONTRACT NO		1	SCALE 1:5
DRAWING No		[B.20]	REVISION No. 0

PHASE	QUANTITY	FINISH
1	1	

A3

GRID LOCATION	
C1	C/6

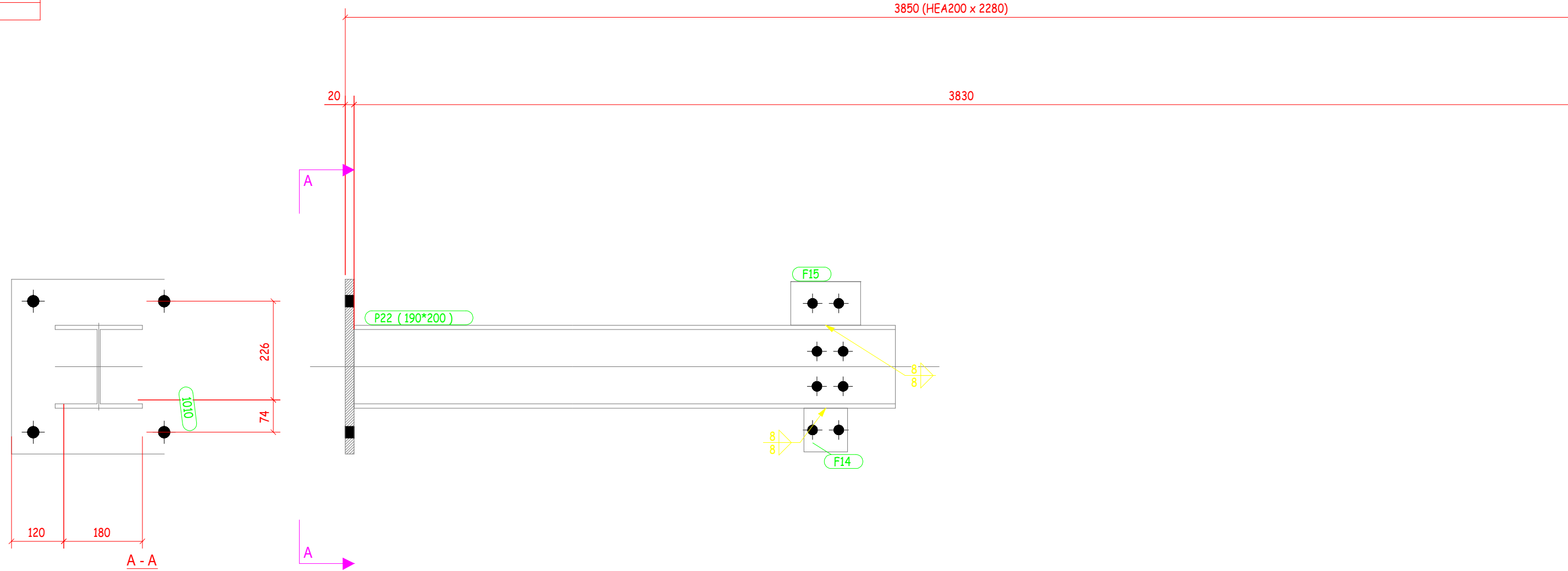

1 No COLUMN Marked C1

GENERAL NOTES:		ALL HOLES ARE	22.0	mm	UNLESS NOTED		
		ALL WELDS ARE	6.0	mm	F.W UNLESS NOTED		
MATERIAL LIST FOR ASSEMBLY MK'D		C1				1	No. Required
Mark	Profile	Material	No.	Length	Area	Weight	
P22	HEA200	S235JR	1	2280	2.6	96.3	
1010	PL2*40	S235JR	1	400	0.4	25.1	
F15	PL2*10	S235JR	1	160	0.0	2.5	
F14	PL2*10	S235JR	1	100	0.0	1.6	
			Total		3.0	125.5	

No	REV MARK	REVISION DESCRIPTION	REV. DATE
DRAWING TITLE		ANGLE	
CONTRACT		Tekla Corporation	
MODELLED BY		ISSUED	
CONTRACT NO		1	SCALE 1:10
DRAWING No		[C.1]	REVISION No. 0

PHASE	QUANTITY	FINISH
1	1	

A3

GRID LOCATION	
C3	M/2



1 No COLUMN Marked C3

PHASE	QUANTITY	FINISH
1	1	

GENERAL NOTES:						
			ALL HOLES ARE	22.0	mm UNLESS NOTED	
			ALL WELDS ARE	6.0	mm F.W UNLESS NOTED	
MATERIAL LIST FOR ASSEMBLY MK'D						
			C3	1	No. Required	
Mark	Profile	Material	No.	Length	Area	Weight
P10	HEA200	S235JR	1	4980	5.7	210.4
1003	PL2*40	S235JR	1	400	0.4	25.1
Total					6.0	235.6

No	REV MARK	REVISION DESCRIPTION	REV. DATE
DRAWING TITLE		COLUMN	
CONTRACT		Tekla Corporation	
MODELLED BY		ISSUED	
CONTRACT NO		1	SCALE 1:5
DRAWING No		[C.3]	REVISION No. 0

A3

GRID LOCATION	
B10	G-M/2-3
B10	G-M/3-4
B10	G-M/7-8
B10	G-M/8-9

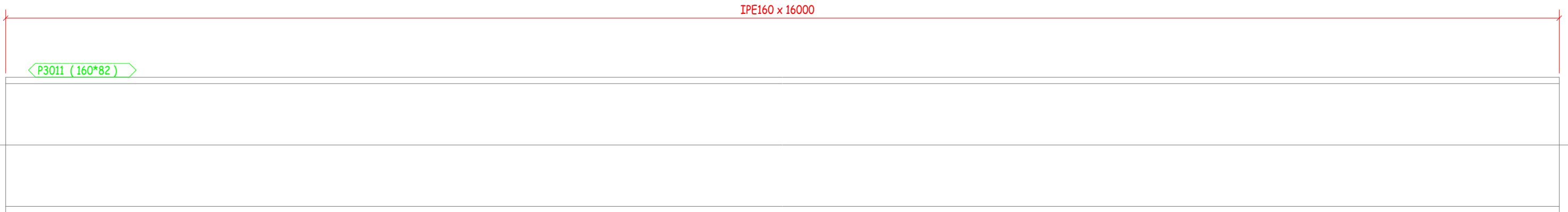

5 No BEAM Marked B10

GENERAL NOTES: ALL HOLES ARE 22.0 mm UNLESS NOTED
ALL WELDS ARE 6.0 mm F.W UNLESS NOTED

MATERIAL LIST FOR ASSEMBLY MK'D						
		B10			5 No. Required	
Mark	Profile	Material	No.	Length	Area	Weight
P3011	IPE160	S235JR	1	16000	10.0	252.3
Total					10.0	252.3

No	REV MARK	REVISION DESCRIPTION	REV. DATE
DRAWING TITLE		COLUMN	
CONTRACT		Tekla Corporation	
MODELLED BY		ISSUED	
CONTRACT NO		1	SCALE 1:5
DRAWING No		[B.10]	REVISION No. 0

PHASE	QUANTITY	FINISH
1	5	

A3

GRID LOCATION	
B18	E-F/7-8
B18	E-F/8-9
B18	F-G/7-8
B18	F-G/8-9
B18	G-H/7-8
B18	G-H/8-9
B18	H-J/7-8
B18	H-J/8-9
B18	J-K/2-3
B18	J-K/7-8
B18	J-K/8-9

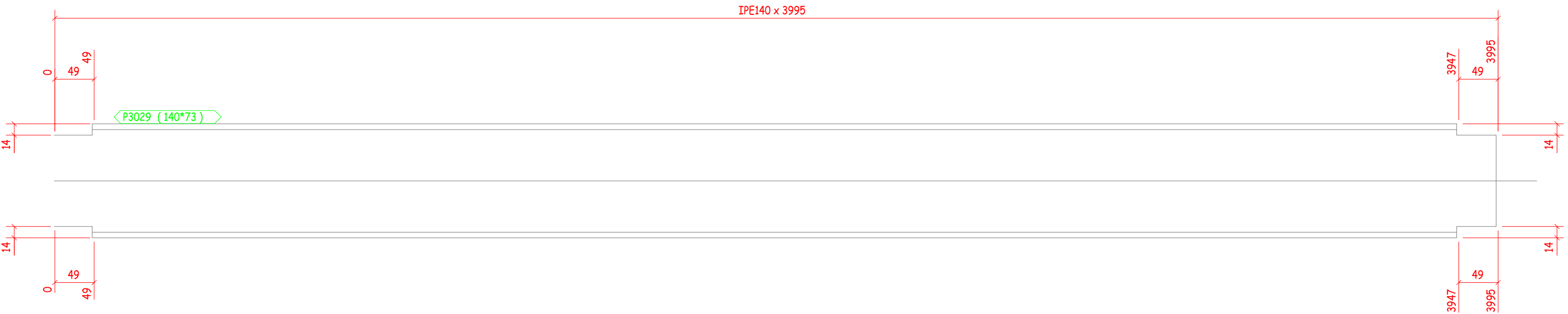

16 No BEAM Marked B18

GENERAL NOTES: ALL HOLES ARE 22.0 mm UNLESS NOTED
ALL WELDS ARE 6.0 mm F.W UNLESS NOTED

MATERIAL LIST FOR ASSEMBLY MK'D						
			B18		16 No. Required	
Mark	Profile	Material	No.	Length	Area	Weight
P3029	IPE140	S235JR	1	3995	2.2	51.4
			Total		2.2	51.4

No	REV MARK	REVISION DESCRIPTION	REV. DATE
DRAWING TITLE		COLUMN	
CONTRACT		Tekla Corporation	
MODELLED BY		ISSUED	
CONTRACT NO		1	SCALE 1:5
DRAWING No		[B.18]	REVISION No. 0

PHASE	QUANTITY	FINISH
1	16	

A3

GRID LOCATION	
B14	K-M/7-8
B14	K-M/8-9

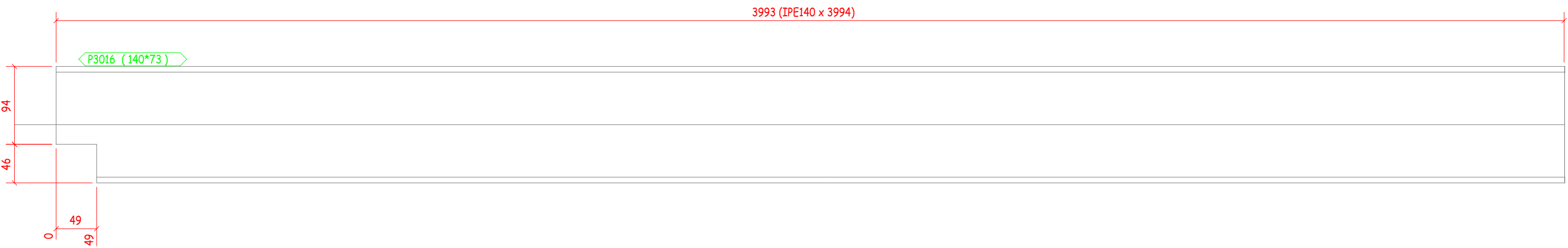

3 No BEAM Marked B22

GENERAL NOTES:		ALL HOLES ARE	22.0	mm UNLESS NOTED		
		ALL WELDS ARE	6.0	mm F.W UNLESS NOTED		
MATERIAL LIST FOR ASSEMBLY MK'D		B14 3 No. Required				
Mark	Profile	Material	No.	Length	Area	Weight
P3016	IPE140	S235JR	1	3994	2.2	51.4
			Total		2.2	51.4

No	REV MARK	REVISION DESCRIPTION	REV. DATE
DRAWING TITLE		COLUMN	
CONTRACT		Tekla Corporation	
MODELLED BY		ISSUED	
CONTRACT NO		1	SCALE 1:5
DRAWING No		[B.14]	REVISION No. 0

PHASE	QUANTITY	FINISH
1	3	

A3

GRID LOCATION	
7	G-H/7
7	H-J/7
7	J-K/7

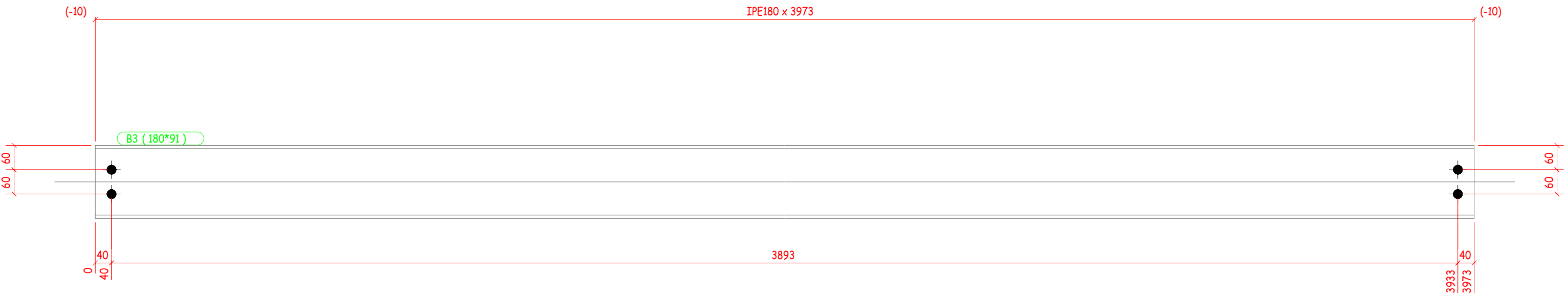

3 No BEAM Marked 7

GENERAL NOTES:						
		ALL HOLES ARE	22.0	mm UNLESS NOTED		
		ALL WELDS ARE	6.0	mm F.W UNLESS NOTED		
MATERIAL LIST FOR ASSEMBLY MK'D						
Mark	Profile	Material	No.	Length	Area	Weight
B3	IPE180	S235JR	1	3973	2.8	74.5
				Total	2.8	74.5

No	REV MARK	REVISION DESCRIPTION	REV. DATE
DRAWING TITLE		ANGLE	
CONTRACT		Tekla Corporation	
MODELLED BY		ISSUED	
CONTRACT NO		1	SCALE 1:10
DRAWING No		[7]	REVISION No. 0

PHASE	QUANTITY	FINISH
1	3	

A3

GRID LOCATION	
B9	A-G/2-3
B9	A-G/3-4
B9	A-G/7-8
B9	A-G/8-9

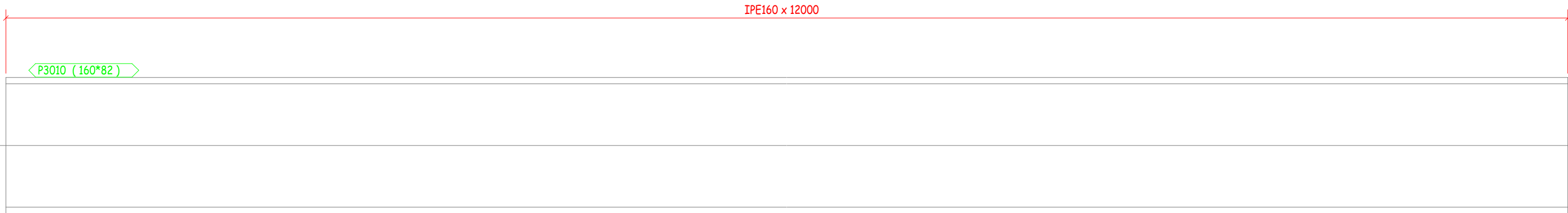

5 No BEAM Marked B9

GENERAL NOTES: ALL HOLES ARE 22.0 mm UNLESS NOTED
ALL WELDS ARE 6.0 mm F.W UNLESS NOTED

MATERIAL LIST FOR ASSEMBLY MK'D						
		B9			5 No. Required	
Mark	Profile	Material	No.	Length	Area	Weight
P3010	IPE160	S235JR	1	12000	7.5	189.2
Total					7.5	189.2

No	REV MARK	REVISION DESCRIPTION	REV. DATE
DRAWING TITLE		COLUMN	
CONTRACT		Tekla Corporation	
MODELLED BY		ISSUED	
CONTRACT NO		1	SCALE 1:5
DRAWING No		[B.9]	REVISION No. 0

PHASE	QUANTITY	FINISH
1	5	

A3

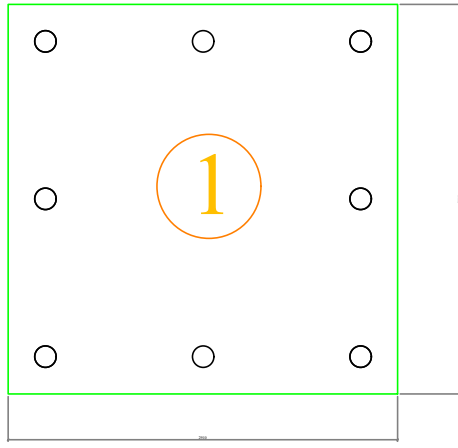

PL/1
20
MM
- 7
ADET

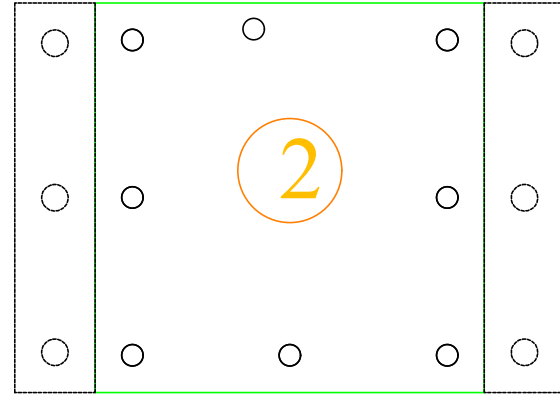

PL/2
20
MM
- 1
ADET

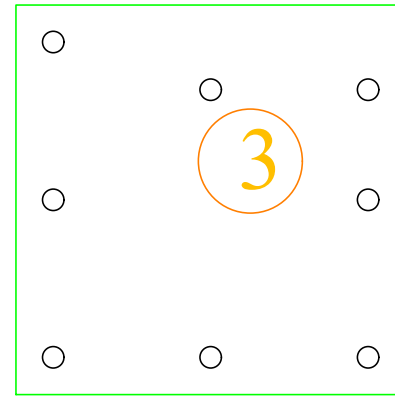

PL/3
20
MM
- 1
ADET

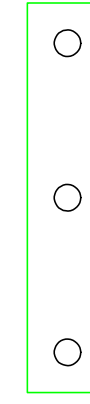

PL/31
-
20
MM

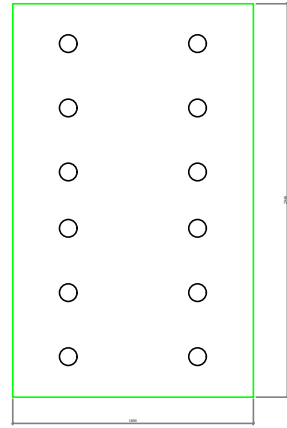

PL/4
15
MM
- 54
ADET

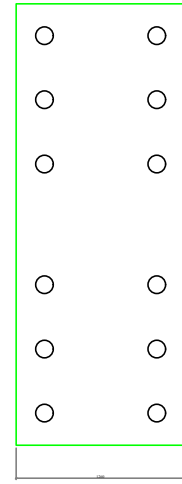

PL/5
15
MM
- 54
ADET

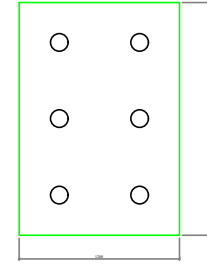

PL/6
10
MM
- 96
ADET

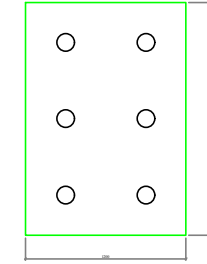

PL/37
15
MM
- 16
ADET

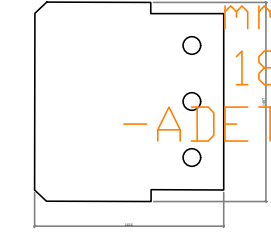

PL/7
10
MM
- 84
ADET

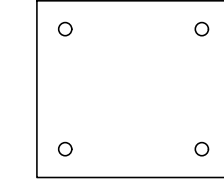

PL/18
10
MM
- 16
ADET

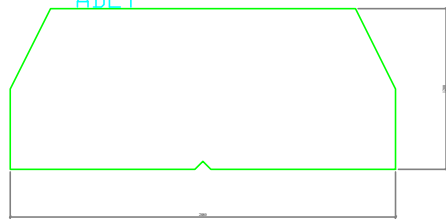

PL/9
10
MM
480*200
- 9
ADET



PL/10
10
MM
90*200
- 36
ADET

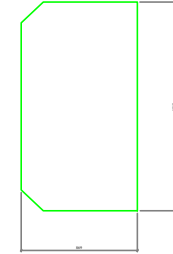

PL/11- 10
MM
145*260
- 236
ADET

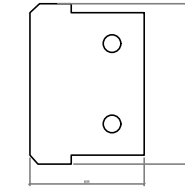

PL/16
10
MM
- 7
ADET

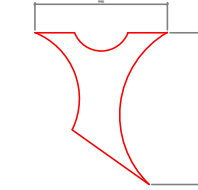

PL/32
10
MM
- 40
ADET

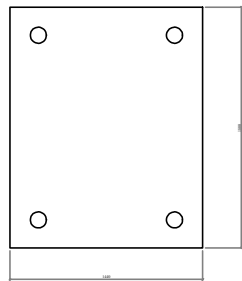

PL/35 10
MM
- 3
ADET

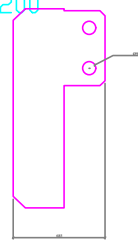

PL/15 8
MM
- 408
ADET

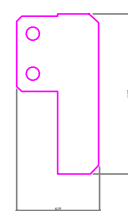

PL/14 8
MM
- 1526
ADET

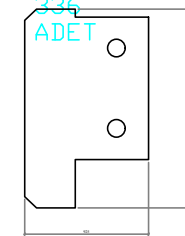

PL/8
10
MM
- 203
ADET

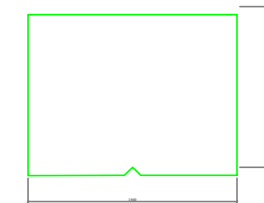

PL/13
10
MM
- 9
ADET

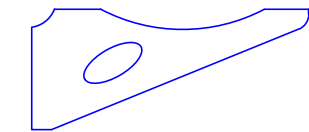

PL/34 10
MM
- 140
ADET

Rev. No	Tarih	Açıklama	İmza	Ürün Adı	??in Ad?	Çizen	Kontrol	Onay
03				Ürün Adı	Yüklenici:			
02				Ürün Kodu	Ürün No:			
01								

PLAZMA KESİM

GRID LOCATION	
C4	E/3
C4	F/3
C4	G/3
C4	H/3
C4	J/3
C4	K/3

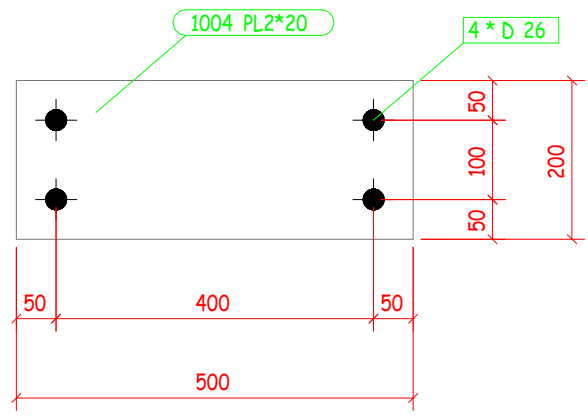
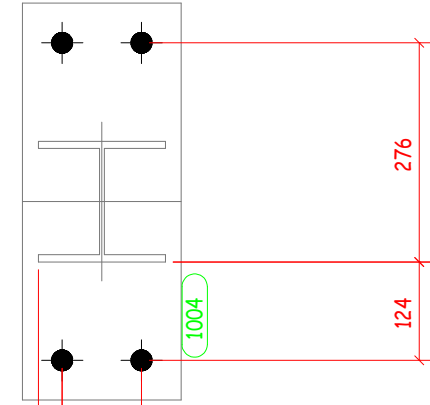
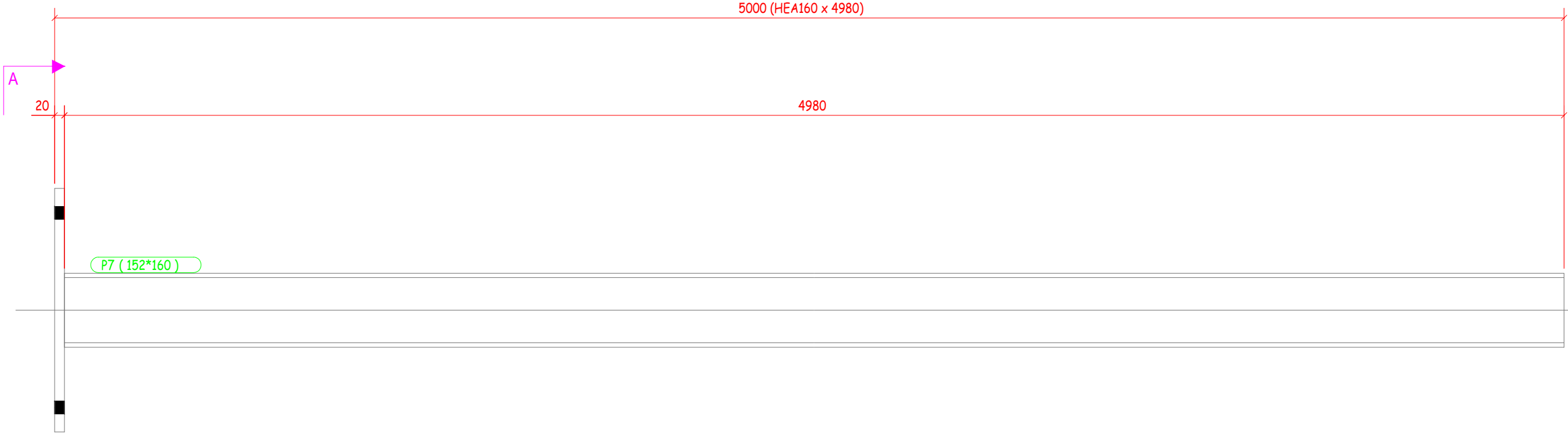

6 No COLUMN Marked C4

GENERAL NOTES:						
			ALL HOLES ARE	22.0	mm UNLESS NOTED	
			ALL WELDS ARE	6.0	mm F.W UNLESS NOTED	
MATERIAL LIST FOR ASSEMBLY MK'D						
			C4		6 No. Required	
Mark	Profile	Material	No.	Length	Area	Weight
P7	HEA160	S235JR	1	4980	4.5	151.6
1004	PL2*20	S235JR	1	500	0.2	15.7
				Total	4.7	167.3

No	REV MARK	REVISION DESCRIPTION	REV. DATE
DRAWING TITLE		ANGLE	
CONTRACT		Tekla Corporation	
MODELLED BY		ISSUED	
CONTRACT NO		1	SCALE 1:10
DRAWING No		[C.4]	REVISION No. 0

PHASE	QUANTITY	FINISH
1	6	

A3

GRID LOCATION	
C5	E/10

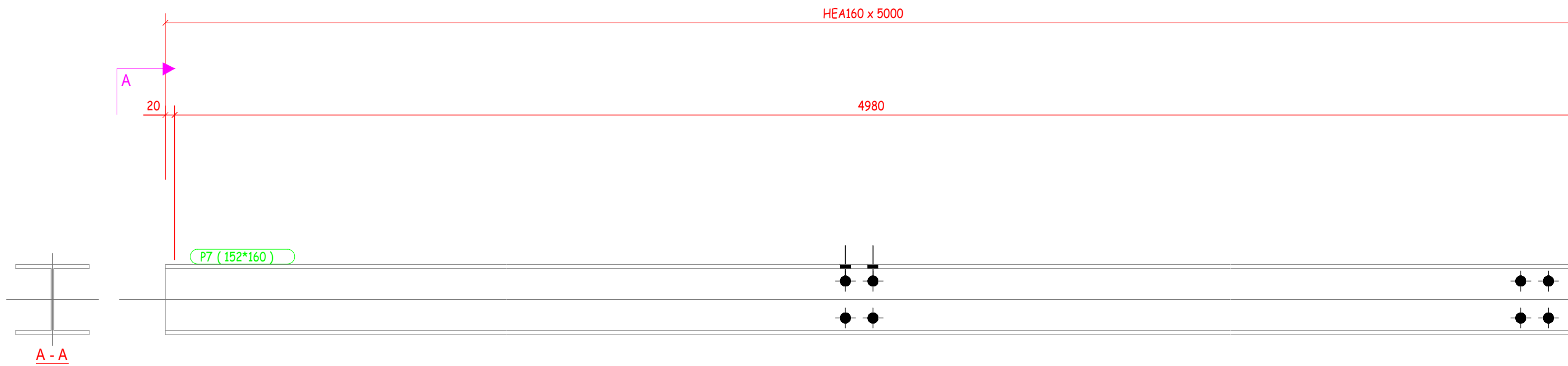

A →

1 No COLUMN Marked C5

GENERAL NOTES: ALL HOLES ARE 22.0 mm UNLESS NOTED
ALL WELDS ARE 6.0 mm F.W UNLESS NOTED

MATERIAL LIST FOR ASSEMBLY MK'D						
Mark	Profile	Material	No.	Length	Area	Weight
P7	HEA160	S235JR	1	5000	4.5	152.2
				Total	4.5	152.2

No	REV MARK	REVISION DESCRIPTION	REV. DATE
DRAWING TITLE		ANGLE	
CONTRACT		Tekla Corporation	
MODELLED BY		ISSUED	
CONTRACT NO		1	SCALE 1:10
DRAWING No		[C.5]	REVISION No. 0

PHASE	QUANTITY	FINISH
1	1	

A3

GRID LOCATION	
0(?)	B-C/6
0(?)	B-D/7
0(?)	C-D/3-4
0(?)	C-D/5
0(?)	C-D/5-6
0(?)	C-D/6
0(?)	C/3-4
0(?)	E-F/7
0(?)	F-G/7
0(?)	G-H/7
0(?)	H-J/7
0(?)	J-K/7
0(?)	K-L/7

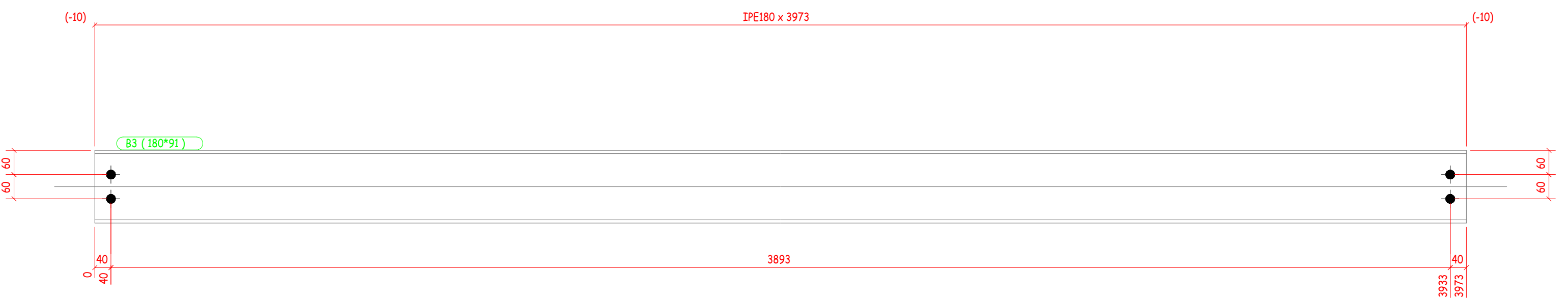

GENERAL NOTES:
 ALL HOLES ARE 0.0 mm UNLESS NOTED
 ALL WELDS ARE 0.0 mm F.W UNLESS NOTED

MATERIAL LIST FOR ASSEMBLY MK'D						
Mark	Profile	Material	No.	Length	Area	Weight
B7	IPE180	S235JR	1	3973	2.8	74.5
				Total	2.8	74.5

No	REV MARK	REVISION DESCRIPTION	REV. DATE
DRAWING TITLE		ANGLE	
CONTRACT		Tekla Corporation	
MODELLED BY		ISSUED	
CONTRACT NO		1	SCALE 1:10
DRAWING No		[7]	REVISION No. 0

PHASE	QUANTITY	FINISH
1	14	

A3

GRID LOCATION	
C1	A/2

3850 (HEA160 x 3830)

3830

20

A

A

P6 (152*160)

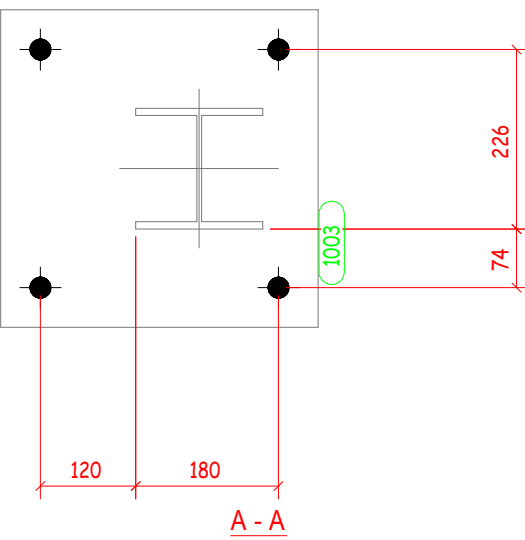

4 * D 26

1003 PL2*40

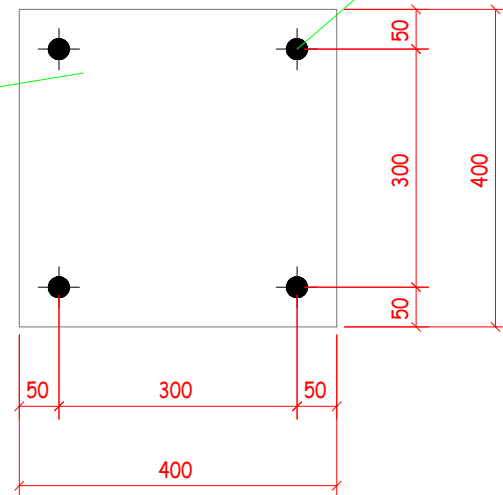

1 No COLUMN Marked C1

GENERAL NOTES:

ALL HOLES ARE 22.0 mm UNLESS NOTED
ALL WELDS ARE 6.0 mm F.W UNLESS NOTED

MATERIAL LIST FOR ASSEMBLY MK'D

			C1		1 No. Required	
Mark	Profile	Material	No.	Length	Area	Weight
P6	HEA160	S235JR	1	3830	3.5	116.6
1003	PL2*40	S235JR	1	400	0.4	25.1
			Total		3.8	141.7

No	REV MARK	REVISION DESCRIPTION	REV. DATE
DRAWING TITLE		ANGLE	
CONTRACT		Tekla Corporation	
MODELLED BY		ISSUED	
CONTRACT NO		1	SCALE 1:10
DRAWING No		[C.1]	REVISION No. 0

PHASE	QUANTITY	FINISH
1	1	

A3

GRID LOCATION	
C3	F/3



1 No COLUMN Marked C3

GENERAL NOTES:						
			ALL HOLES ARE 22.0 mm UNLESS NOTED			
			ALL WELDS ARE 6.0 mm F.W UNLESS NOTED			
MATERIAL LIST FOR ASSEMBLY MK'D						
			C3 1 No. Required			
Mark	Profile	Material	No.	Length	Area	Weight
P3010	IPE160	S235JR	1	12000	7.5	189.2
P8	HEA160	S235JR	1	4980	4.5	151.6
P10	HEA160	S235JR	1	4980	4.5	151.6
P3038	IPE200	S235JR	1	1328	1.0	29.7
1011	PL2*20	S235JR	2	500	0.2	15.7
1020	PL1.5*11	S235JR	1	435	0.1	5.6
2020	PL0.8*11	S235JR	1	352	0.1	2.4
2028	PL0.6*19.848	S235JR	1	352	0.1	1.3
				Total	18.2	562.9

No	REV MARK	REVISION DESCRIPTION	REV. DATE
DRAWING TITLE		COLUMN	
CONTRACT		Tekla Corporation	
MODELLED BY		ISSUED	
CONTRACT NO		1	SCALE 1:10
DRAWING No		[C.3]	REVISION No. 0

PHASE	QUANTITY	FINISH
1	1	

A3

Tekla structures

GRID LOCATION	
C4	E/3
C4	F/3
C4	G/3
C4	H/3
C4	J/3
C4	K/3

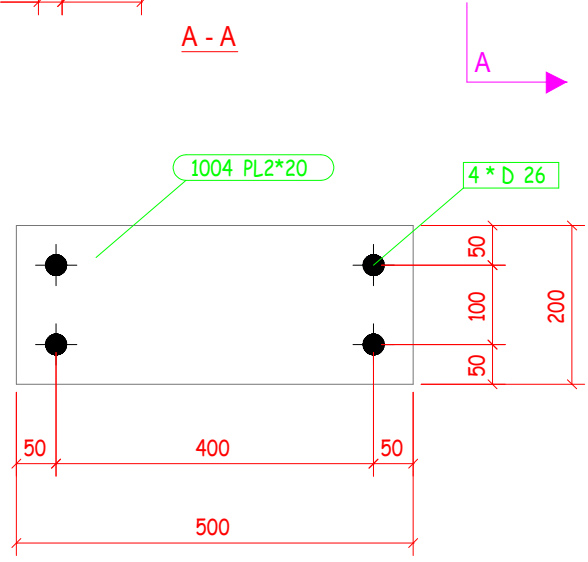
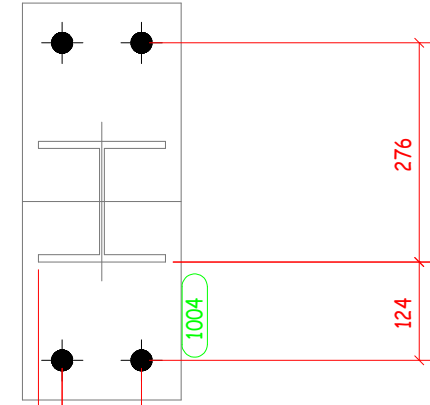
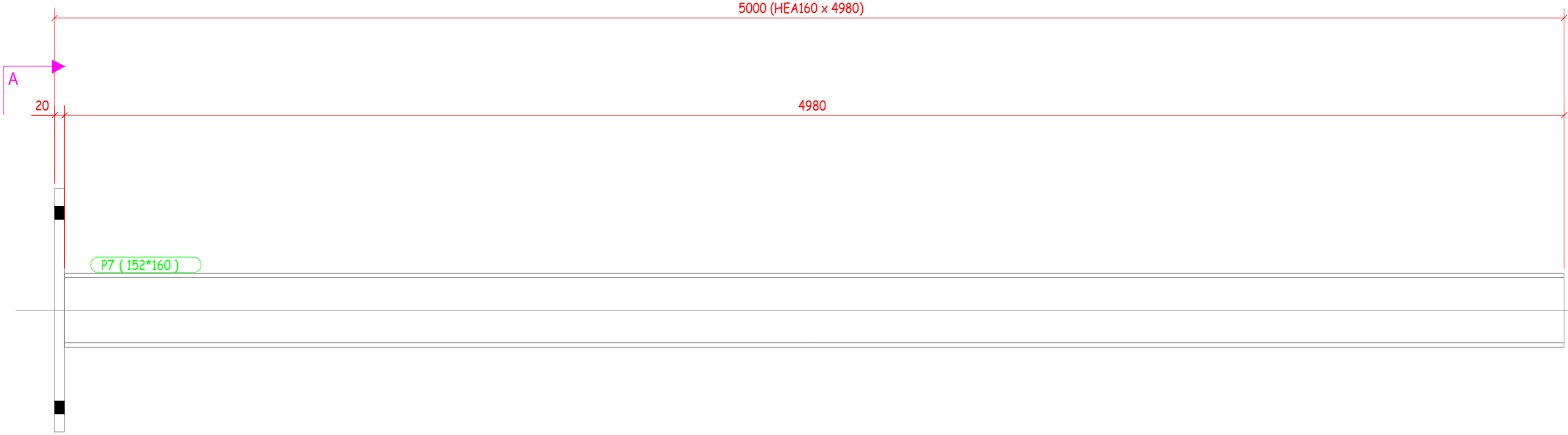

6 No COLUMN Marked C4

GENERAL NOTES:						
			ALL HOLES ARE	22.0	mm UNLESS NOTED	
			ALL WELDS ARE	6.0	mm F.W UNLESS NOTED	
MATERIAL LIST FOR ASSEMBLY MK'D						
Mark	Profile	Material	No.	Length	Area	Weight
P7	HEA160	S235JR	1	4980	4.5	151.6
1004	PL2*20	S235JR	1	500	0.2	15.7
				Total	4.7	167.3

No	REV MARK	REVISION DESCRIPTION	REV. DATE
DRAWING TITLE		ANGLE	
CONTRACT		Tekla Corporation	
MODELLED BY		ISSUED	
CONTRACT NO		1	SCALE 1:10
DRAWING No		[C.4]	REVISION No. 0

PHASE	QUANTITY	FINISH
1	6	

A3

GRID LOCATION	
B14	E-F/8
B14	F-G/8

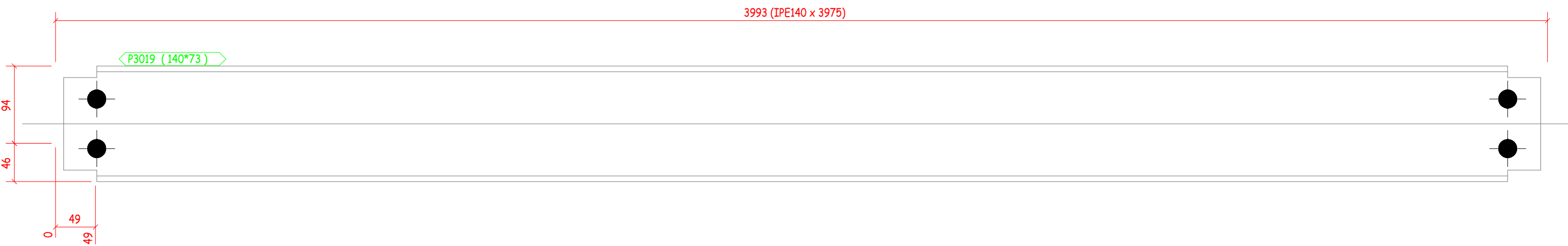

2 No BEAM Marked B14

GENERAL NOTES:		ALL HOLES ARE	22.0	mm UNLESS NOTED		
		ALL WELDS ARE	6.0	mm F.W UNLESS NOTED		
MATERIAL LIST FOR ASSEMBLY MK'D		B14			2	No. Required
Mark	Profile	Material	No.	Length	Area	Weight
P3019	IPE140	S235JR	1	3975	2.2	51.2
			Total		2.2	51.2

No	REV MARK	REVISION DESCRIPTION	REV. DATE
DRAWING TITLE		COLUMN	
CONTRACT		Tekla Corporation	
MODELLED BY		ISSUED	
CONTRACT NO		1	SCALE 1:5
DRAWING No		[B.14]	REVISION No. 0

PHASE	QUANTITY	FINISH
1	2	

A3

GRID LOCATION	
0(?)	B-C/6
0(?)	B-D/7
0(?)	C-D/3-4
0(?)	C-D/5
0(?)	C-D/5-6
0(?)	C-D/6
0(?)	C/3-4
0(?)	E-F/7
0(?)	F-G/7
0(?)	G-H/7
0(?)	H-J/7
0(?)	J-K/7
0(?)	K-L/7

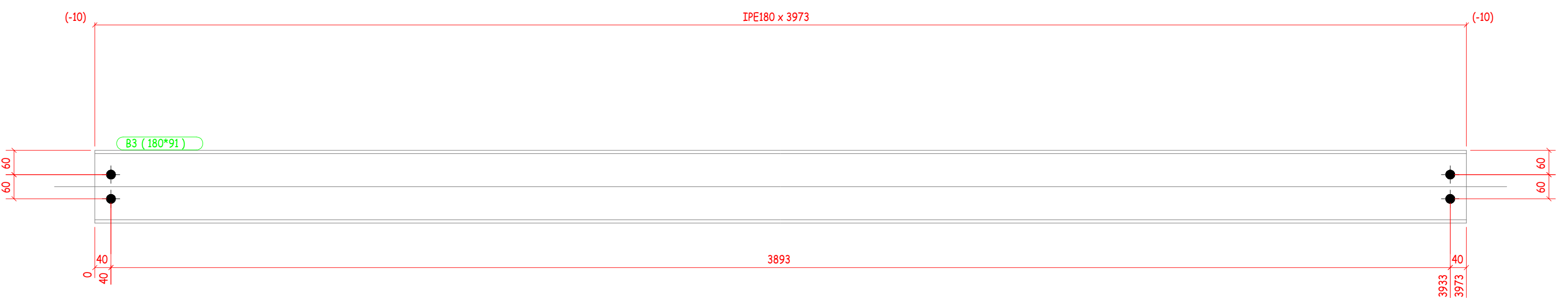

GENERAL NOTES:
 ALL HOLES ARE 0.0 mm UNLESS NOTED
 ALL WELDS ARE 0.0 mm F.W UNLESS NOTED

MATERIAL LIST FOR ASSEMBLY MK'D						
Mark	Profile	Material	No.	Length	Area	Weight
B3	IPE180	S235JR	1	3973	2.8	74.5
				Total	2.8	74.5

No	REV MARK	REVISION DESCRIPTION	REV. DATE
DRAWING TITLE		ANGLE	
CONTRACT		Tekla Corporation	
MODELLED BY		ISSUED	
CONTRACT NO		1	SCALE 1:10
DRAWING No		[7]	REVISION No. 0

PHASE	QUANTITY	FINISH
1	14	

A3

GRID LOCATION	
B15	K-M/8

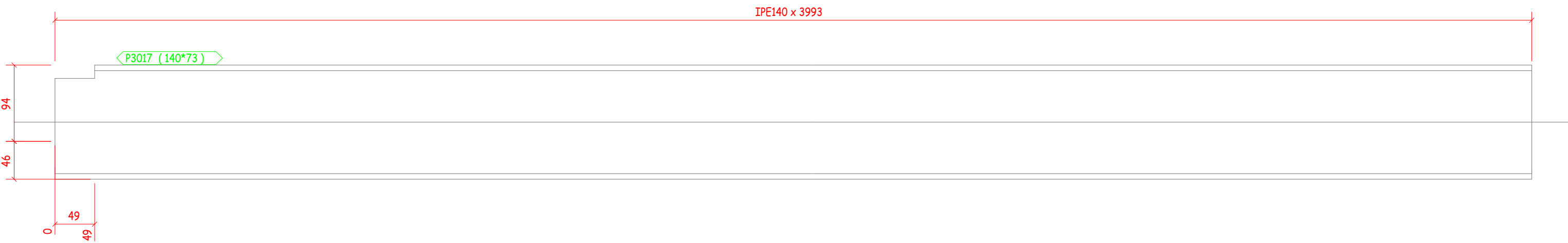

1 No BEAM Marked B15

GENERAL NOTES:		ALL HOLES ARE	22.0	mm UNLESS NOTED		
		ALL WELDS ARE	6.0	mm F.W UNLESS NOTED		
MATERIAL LIST FOR ASSEMBLY MK'D		B15			1	No. Required
Mark	Profile	Material	No.	Length	Area	Weight
P3017	IPE140	S235JR	1	3993	2.2	51.4
				Total	2.2	51.4

No	REV MARK	REVISION DESCRIPTION	REV. DATE
DRAWING TITLE		COLUMN	
CONTRACT		Tekla Corporation	
MODELLED BY		ISSUED	
CONTRACT NO		1	SCALE 1:5
DRAWING No		[B.15]	REVISION No. 0

PHASE	QUANTITY	FINISH
1	1	

A3

GRID LOCATION	
B11	A-M/6-7

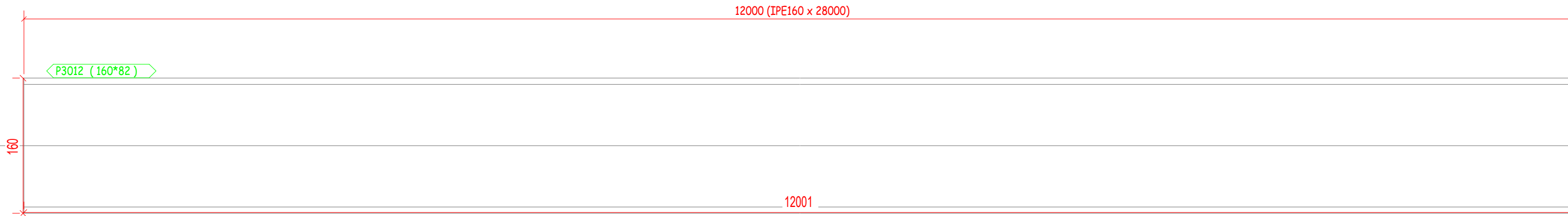

1 No BEAM Marked B11

GENERAL NOTES: ALL HOLES ARE 22.0 mm UNLESS NOTED
ALL WELDS ARE 6.0 mm F.W UNLESS NOTED

MATERIAL LIST FOR ASSEMBLY MK'D						
			B11		1 No. Required	
Mark	Profile	Material	No.	Length	Area	Weight
P3012	IPE160	S235JR	1	28000	17.4	441.6
Total					17.4	441.6

No	REV MARK	REVISION DESCRIPTION	REV. DATE
DRAWING TITLE		COLUMN	
CONTRACT		Tekla Corporation	
MODELLED BY		ISSUED	
CONTRACT NO		1	SCALE 1:5
DRAWING No		[B.11]	REVISION No. 0

PHASE	QUANTITY	FINISH
1	1	

A3

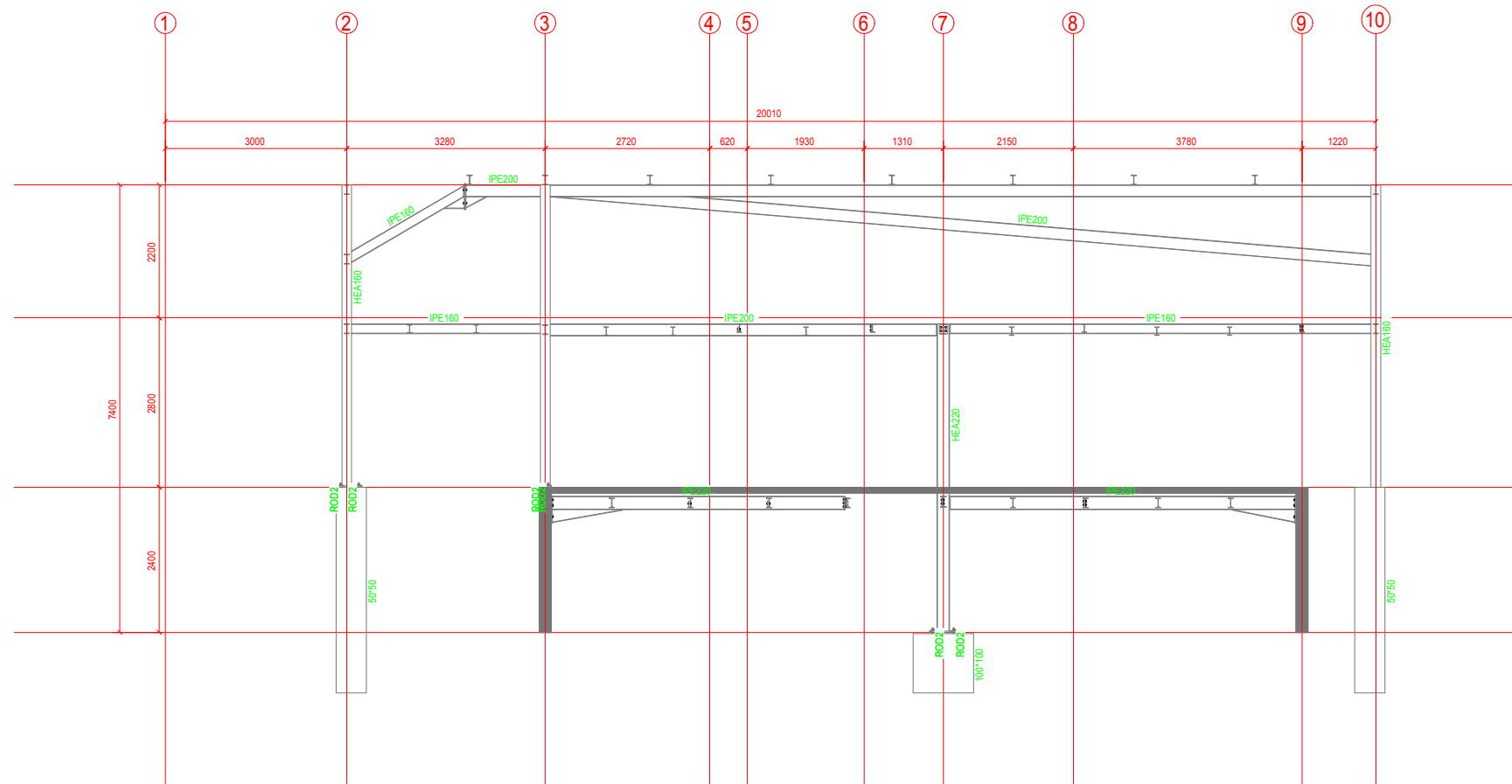

K-K KESİTİ

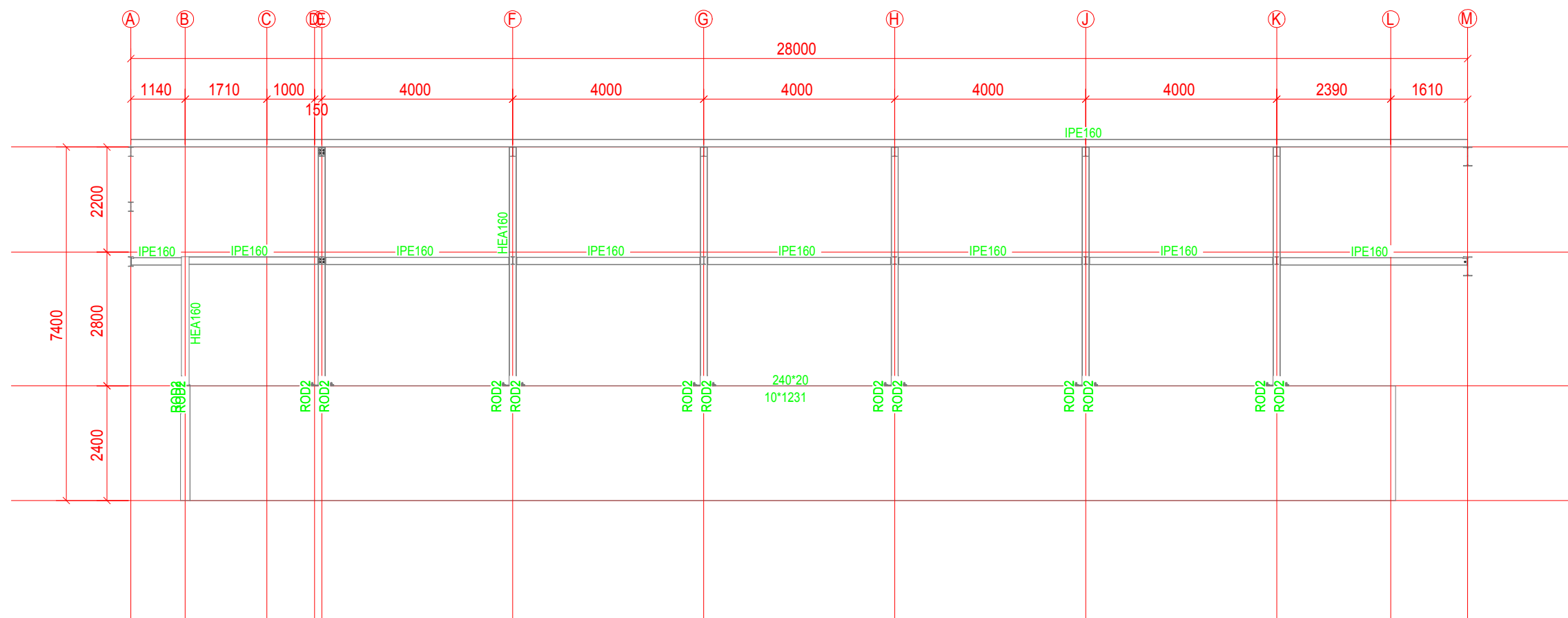

3-3 KESİTİ

Rev	Description	Date	Created	Approved
	Client			
	Project		Project Number	
	Tekla Corporation			
	Drawing Title			
	3D VIEW OF STRUCTURE			
	Drawn by	Scale @A1	1:100	
	Designed by	Date		
	Checked by	Drawing Number	ENTER DRG	
	Approved by	Revision		

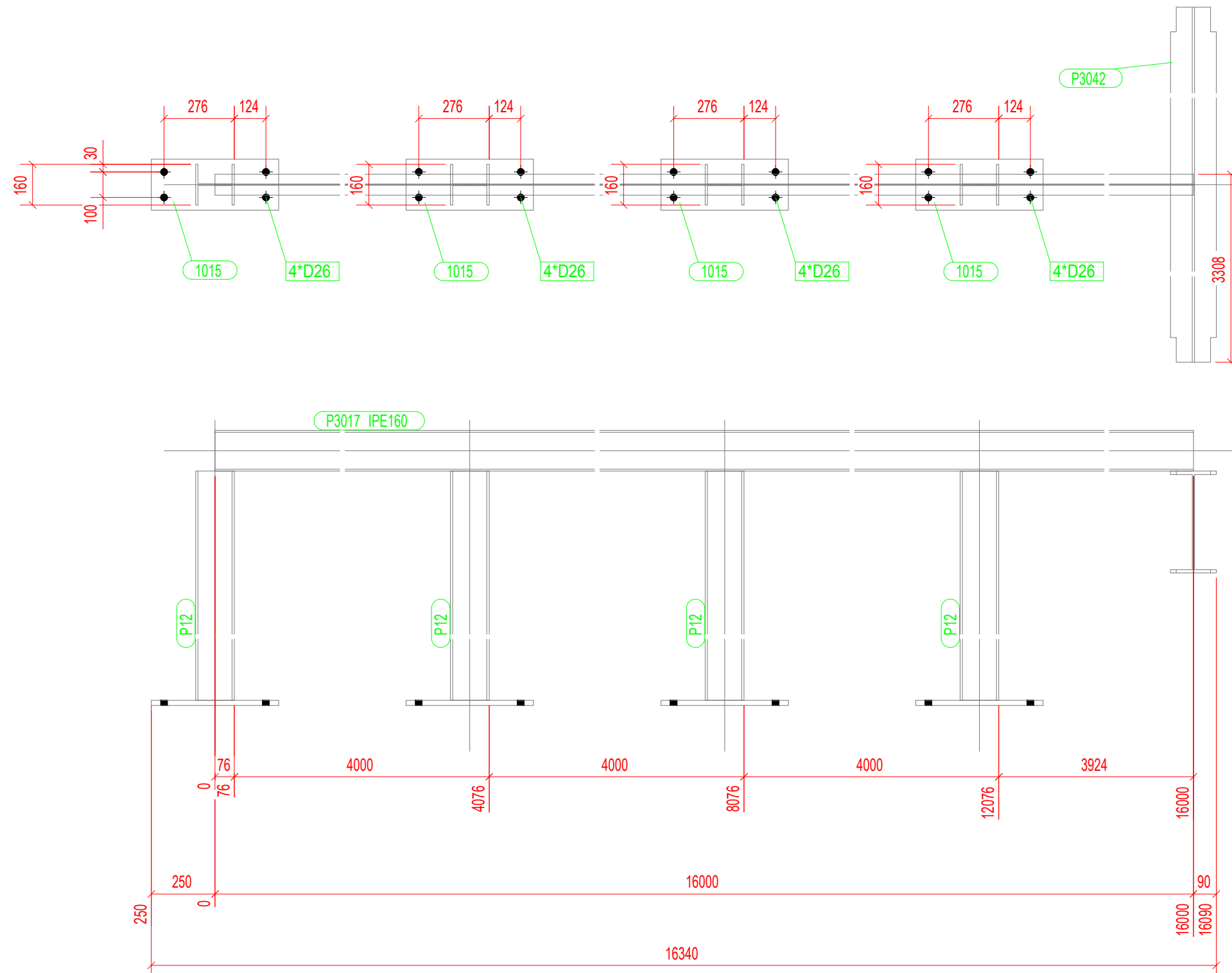

B1 No 1 BEAM

PHASE	QUANTITY
1	1

GENERAL NOTES: ALL HOLES ARE 22.0 mm UNLESS NOTED
ALL WELDS ARE 6.5 mm F.W UNLESS NOTED

MATERIAL LIST FOR ASSEMBLY MK'D						
Mark	Profile	Material	No.	Length	Area	Weight
P3017	IPE160	S235JR	1	16000	10.0	252.3
1015	PL2*20	S235JR	4	500	0.2	15.7
P12	HEA160	S235JR	4	4980	4.5	151.6
P3042	IPE400	S235JR	1	5974	8.8	396.2
Total					37.7	1317.6

No	REV MARK	REVISION DESCRIPTION	CREATED	APPROVED	REV. DATE
DRAWING TITLE		STANDARD			
CONTRACT		Tekla Corporation			
MODELLED BY		ISSUED			
CONTRACT NO		1	SCALE		1:20
DRAWING No		[B.1]	REVISION No.		0

A3